

Contents

	Page
Permanent Formwork Edge Trim	16-1
Additional Options	16-2



Permanent Formwork Edge Trim

Permanent Formwork Edge Trim

Cast-in metal edge trim to suit your project requirements. Accurately produced to provide permanent formwork. Available with a galvanised protective coating in varying heights to suit your dedicated details. Corner chafers can be incorporated as well as cast-in channel inserts.

Typical details

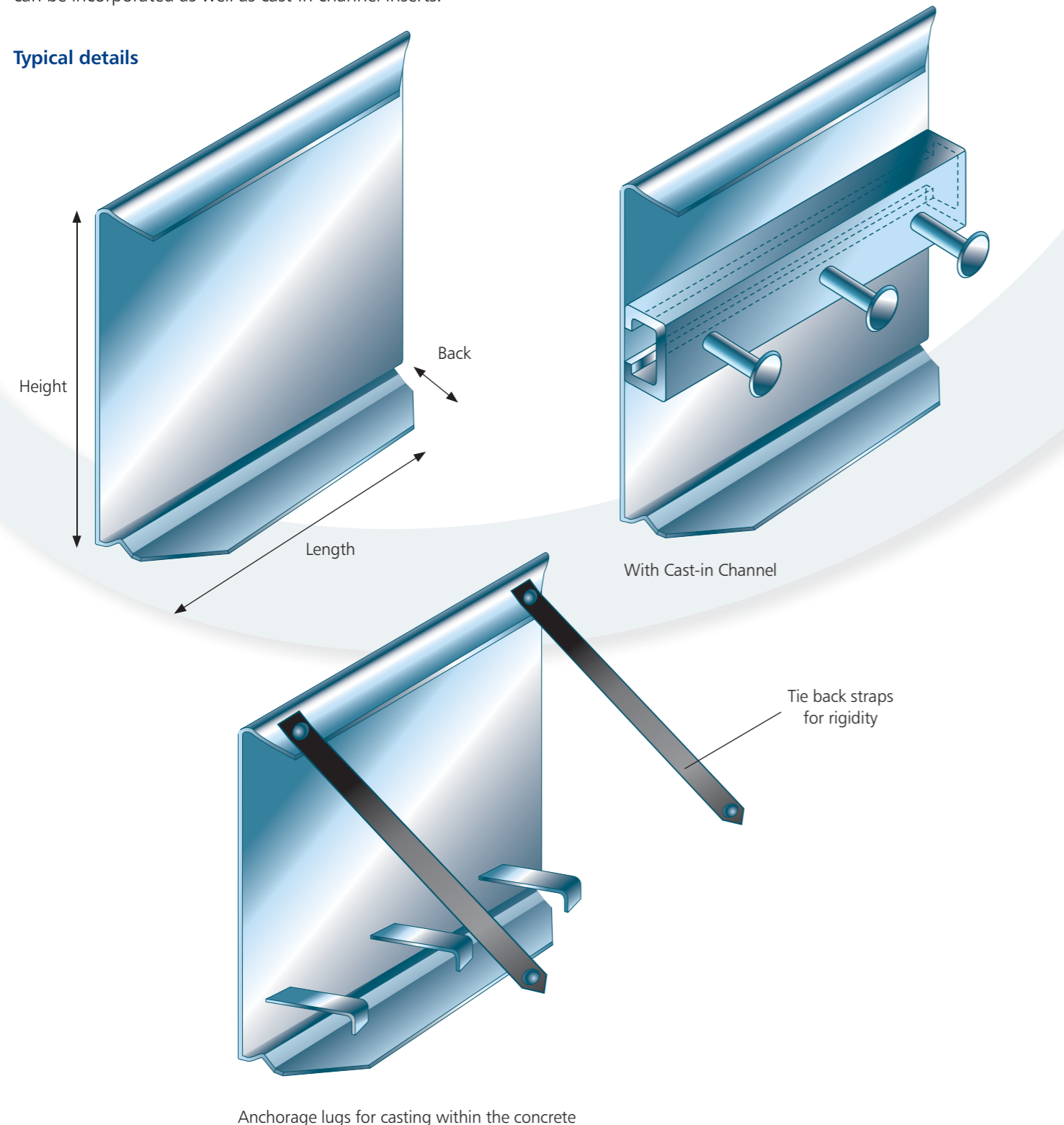

Additional Options

Supplied with anchoring lugs for casting-in to concrete and also tie back straps to provide rigidity to the vertical edge.

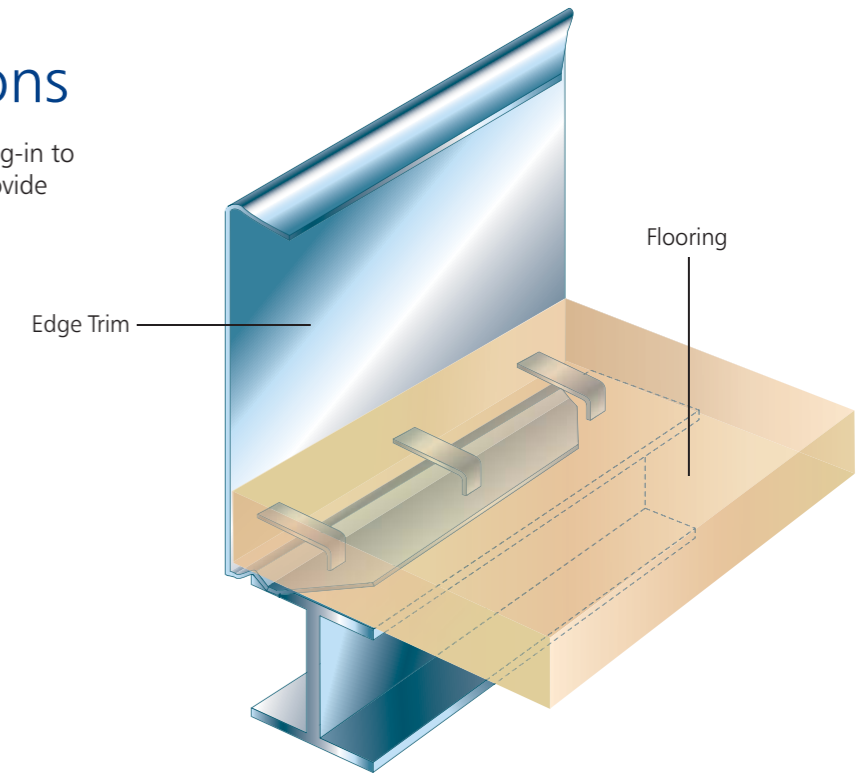

Typical profile variations

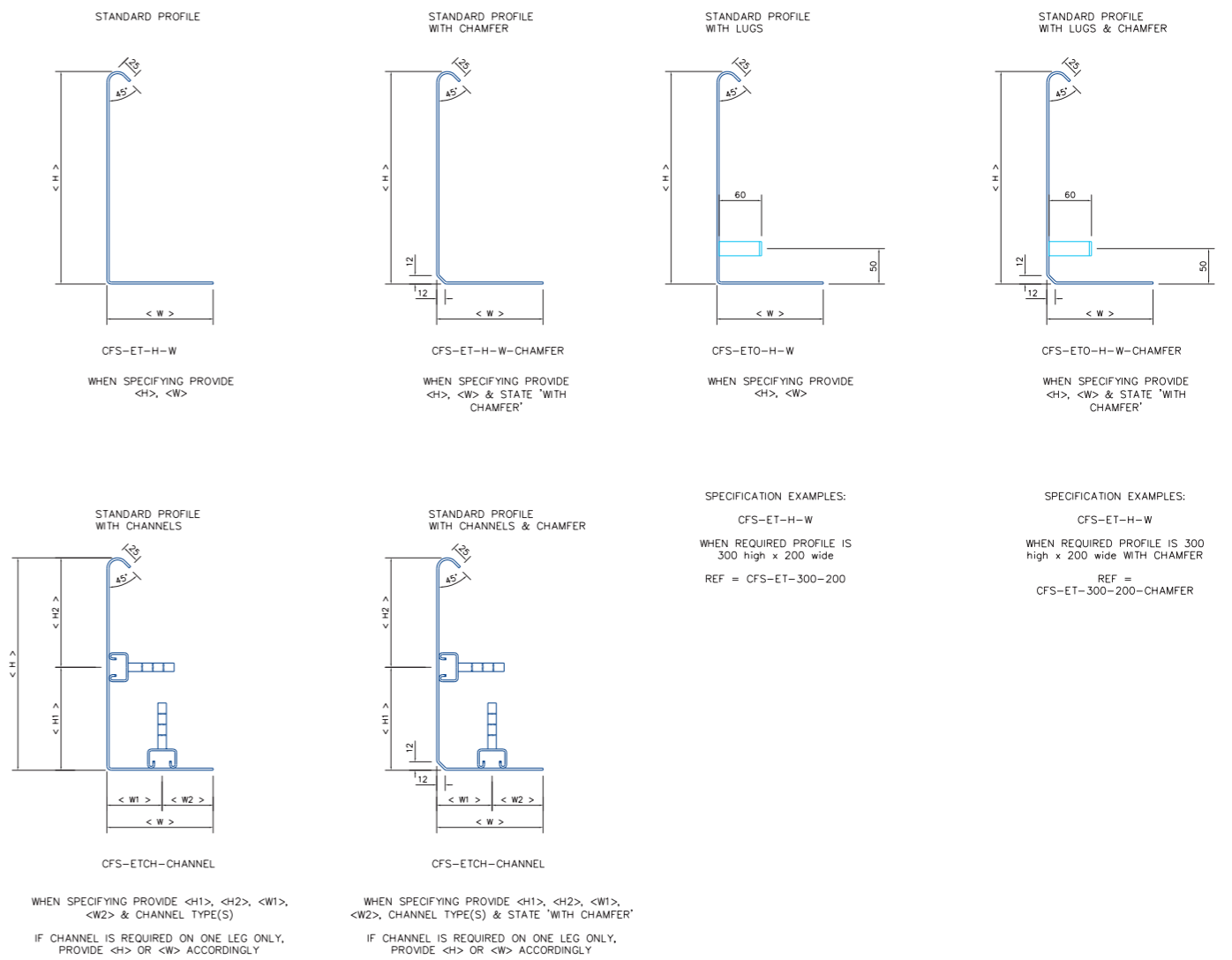

PERMANENT FORMWORK EDGE TRIM