



# LIFTING SYSTEMS DESIGN CRITERIA

01

# CONTENTS

Lifting Systems Design Criteria	1-3
Applied Load on Each Anchor	1-6

# LIFTING SYSTEMS DESIGN CRITERIA

# LIFTING SYSTEMS DESIGN CRITERIA

We have four main systems available for the lifting of precast concrete units. The reasons for selection may be technical, economic, or may be due to the lifting equipment already owned.

CFS can supply all the accessories you need including lifting loops, clutches and recess formers for each of these systems.

All the lifting sockets are slightly oversized so that the threads can still be used in the conditions of building sites.

---

## Threaded Sockets

These are usually used for light to medium-weight units, they are easy to install in the concrete element and may be recessed if required.

Wavy Tail anchors are particularly easy to fix, High Load Wavy Tail anchors may require no further reinforcement. Tube and flat plate sockets are also available, which depend on separate reinforcement.



---

## Cast-in Loops

These anchors require no further accessories as the loop is attached directly to the crane hook.

They are economic where smaller numbers are required, as you do not have to buy a lifting clutch.

They can be used for units where the area around the lifting point is not visible in their permanent condition, as the loop is cast into the top of the concrete.



---

## Quick Lift System

This is an economic option available for lifting light to medium-weight precast concrete.



---

## Spherical Head Anchors

These anchors may be used for any lift, up to very heavy units. They are recessed into the concrete and may require no additional reinforcement, depending on the application.



### Threaded Socket pressed on steel rebar

The "straight" and "long wavy tail" versions are suitable for use in narrow walls, e.g. precast concrete garages. It can carry very high axial and shear loads. In thicker walls it is often more economic to use the "short wavy tail" version.



### Threaded sockets with cross hole

A steel reinforcing bar is passed through the hole to anchor the socket. Owing to the flexible anchorage options, these sockets can be used in the most diverse components - walls, slabs, panels, pipes, etc.



### Sockets with plates and bolts

Owing to their relatively small depth, these sockets are ideal for fitting in slab-type elements perpendicular to the plane of the element.

The end plate increases the anchorage effect.

Schroeder lifting sockets are available with Rd and M threads. To distinguish the threads, M threads have a yellow chromate coating, Rd threads a silver blue chromate coating.



### Threaded sockets in stainless steel with friction-welded steel rebar

The technically sophisticated solution:

- no bare steel at the base of the socket
- no further corrosion protection measures required
- friction welding is an established means of joining for engineered structures
- with metric thread
- a true stainless steel fitting



### Selection of type within an anchor system

You must consider if the anchor is to be used in the edge of walls as (1), in slabs (2) or in beams (3), and also whether the unit will need to be tilted using the anchor, or simply be used for vertical lifting.

With these factors in mind, review the different types of anchors within this catalogue to decide which is most suitable for your application. If in doubt, please contact us for advice.

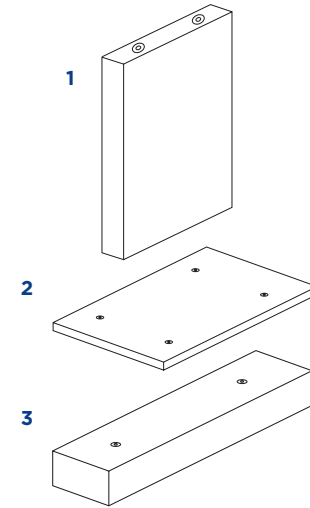

### Load Cases

You must consider the unit over its life until it reaches its permanent destination. The load cases may have different direction of action which must be considered as the anchors have different capacities in axial, angled and shear lifting.

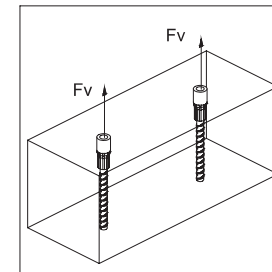

Axial Lift

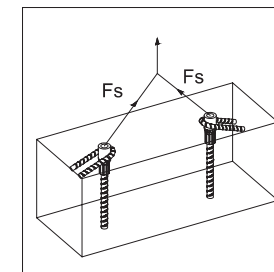

Angled Lift up to a spread of 90°, or 45° from the vertical

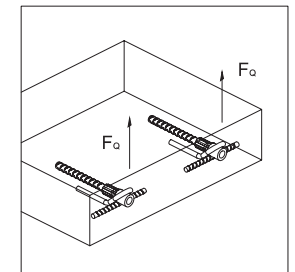

Shear Lift

### Typically there are six possible load cases that may be critical:

1. Demoulding by vertical lift from formwork at precast yard
2. Demoulding by tilting to vertical from formwork at precast yard
3. Handling vertically at precast yard
4. Tilting onto transport or storage at precast yard
5. Tilting from transport or storage on site
6. Handling vertically on site

Typically handling at the precaster is with low strength concrete, but in a more controlled manner. On site the concrete is more mature, but may receive rougher treatment.

# APPLIED LOAD ON EACH ANCHOR

The way in which a unit is lifted influences the load that is applied to the anchors. For each load case that applies to your unit, the following factors must be considered:

## Weight of the Unit, $F_v$

This should be the unfactored weight.

Typically:

$$F_G = V \times \gamma \quad F_G = \text{self weight [kN]}$$

$$V = \text{Volume [m}^3\text{]}$$

$\gamma$  = specific weight of the precast element [kN/m<sup>3</sup>]

Typically  $\gamma$  = 25 kN/m<sup>3</sup>

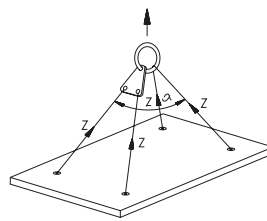
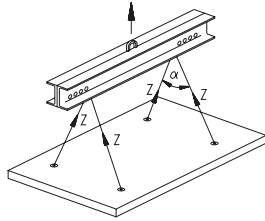
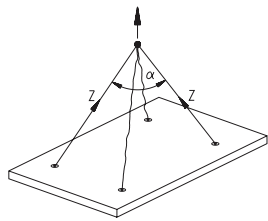

The use of two anchors is usual for beams and upright panels, and four anchors installed symmetrically to the load centre is recommended for horizontal slabs.

## Position of the Anchors

If the anchors cannot be placed symmetrically to the centre of gravity, the load on the anchors must be calculated according to simple static analysis.

## Chain Angles

If no spreader beam is used, the spread angle  $\alpha$  depends on the arrangement and length of the suspending cable.

The resulting horizontal component increases the tensile force on the anchor.

Spread Angle		Spread Coefficient
$\alpha$	$\beta$	$z$
0°	0°	1
15°	7.5°	1.01
30°	15°	1.04
45°	22.5°	1.08
60°	30°	1.16
75°	37.5°	1.26
90°	45°	1.41

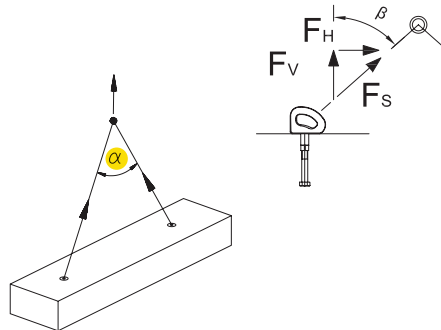

## Number of lifting points, N

Two legged slings are statically determinate. N=2

Three legged slings are statically determinate provided the anchors are not in one line. N=3

Four legged slings are statically indeterminate. It must be assumed that only two anchors are holding the load at any one time. N=2

A spreader beam or tri-plate can make a four legged sling statically determinate. N=4

## Dynamic Factors

The dynamic process of lifting a unit adds load to the anchors. The magnitude of this dynamic effect is determined by the choice of lifting equipment, the length and type of cable or chain, and the hoisting speed.

Cables made of steel or synthetic fibre have a damping effect that increases with cable length. The table below provides typical values that you can use. If you are unsure as to which factor to apply please consult CFS.

Lifting Equipment	Typical Dynamic Impact Factor, $\psi$
Tower crane, Overhead crane, Portal crane	1.2 <sup>a</sup>
Mobile Crane	1.3
Lifting and moving on flat terrain	2.0-2.5
Lifting and moving on rough terrain	3-4

<sup>a</sup> In precasting factories and if specific provisions are made at the building site lower values may be appropriate

## Demoulding Adhesion to Formwork

Adhesion forces between the formwork and the concrete vary according to the type of formwork used.

The following may be taken as a guide:

Formwork Type	Adhesion coefficient, $q_{adh}$ (kN/m <sup>2</sup> )
Oiled steel formwork	1
Varnished timber formwork	2
Rough formwork	3

$$F_{adh} = q_{adh} \times A$$

$$F_{adh} = \text{Adhesion Force [kN]}$$

$$q_{adh} = \text{Adhesion forces [kN/m}^2\text{]}$$

$$A = \text{Surface area in contact with the formwork prior to lifting [m}^2\text{]}$$

Ribbed and waffle panels cause more adhesion. Please contact CFS for advice if required.

## CALCULATION OF THE ACTION FOR EACH LOAD CASE

### Demoulding Vertically (Loadcase 1) – Axial or Angled Lift

$$E_1 = \frac{(F_G + F_{adh}) \times z}{N}$$

E = Action (kN)

F<sub>G</sub> = Weight of Unit (kN)

F<sub>adh</sub> = Adhesion Force (kN)

z = Spread Coefficient

N = Number of Lifting Points

\*Loadcase 1 must be compared with Loadcase 3. Sometimes calculation with dynamic impact factor might be higher. Higher value must be chosen for the lifting system.

### Demoulding by Tilting (Loadcase 2) – Shear Lift

$$E_2 = \frac{(F_G + F_{adh}) \times z}{2N}$$

E = Action (kN)

F<sub>G</sub> = Weight of Unit (kN)

F<sub>adh</sub> = Adhesion Force (kN)

z = Spread Coefficient

N = Number of Lifting Points

\*Loadcase 2 must be compared with Loadcase 4. Sometimes calculation with dynamic impact factor might be higher. Higher value must be chosen for the lifting system.

In this situation half the weight is resting on the formwork.

### Handling Vertically (Loadcases 3 and 6) – Axial or Angled Lift

$$E_3 \text{ or } E_6 = \frac{F_G \times \psi \times z}{N}$$

E = Action (kN)

F<sub>G</sub> = Weight of Unit (kN)

ψ = Dynamic Impact Factor

z = Spread Coefficient

N = Number of Lifting Points

### Tilting (Loadcases 4 and 5) with Shear Lift

$$E_4 \text{ or } E_5 = \frac{F_G \times \psi \times z}{2N}$$

E = Action (kN)

F<sub>G</sub> = Weight of Unit (kN)

ψ = Dynamic Impact Factor

z = Spread Coefficient

N = Number of Lifting Points

In this situation half the weight is resting on the formwork.

### Capacity of anchors

The capacity of each anchor (R) is determined by several factors. These include concrete strength, anchor distance to edges and available reinforcement.

The capacities under commonly occurring situations are found in the tables in each section of this catalogue.

The tables provided within this catalogue provide the capacity, or load resistance of each anchor in most conditions encountered.

If you have a situation outside of the conditions in this catalogue, please contact CFS with a drawing and description of your circumstances and we will provide advice.

For each load case, ensure that

$$R \geq E$$

R = Capacity (kN)

E = Action (kN)

